



PIOTR WANG POWER TRADING CO.,LTD

www.queenbattery.com.cn

锂离子电芯规格书

Specification for Lithium-ion Rechargeable Cell

电芯型号 : **QB18650-2000**

Cell Type : **QB18650-2000**

Prepared By/Date 编制/日期	Checked By/Date 审核/日期	Approved By/Date 批准/日期
黄文荣/2019-01-22	袁青坪/2019-01-22	吕遐博/2019-01-22

	Signature 确认	Date 日期
Customer Approval 客户批准	Company Name: 公司名称:	
	Company Stamp: 客户印章:	

Serial Number 序号	Change item 修改项目	Change Content 修改内容	修改人 PIC	修改日期 Date
A/00	无	初次发行	黄文荣	2019.1.29

1 Preface 前言

This specification describes the type and size, performance, technical characteristics, warning and caution of the lithium ion rechargeable cell. The specification only applies to **QB18650-2000** cell supplied by PIOTR WANG POWER TRADING CO.,LTD

本标准描述了圆柱型锂离子电芯的外型尺寸、特性、技术要求及注意事项。本标准适用于皮特王能源贸易有限公司生产的圆柱型 **QB18650-2000** 锂离子电芯。

2 Description and model 电芯说明及型号

Description: Cylindrical Li-ion rechargeable cell

圆柱锂离子二次电芯

Model: **QB18650-2000mAh**

型号: **QB18650-2000mAh**

3 Cell specification 电芯基本特性

ITEM 项目	SPECIFICATION 特性
Normal capacity 标称容量	2000mAh(0.2C)
Minimum capacity 最小容量	1900mAh (0.2C) (Discharge the cell from 4.2V to 2.75V by 0.2C current) (电芯以 0.2C 从 4.2V 放电至 2.75V)
Normal voltage 标称电压	3.7V
Charge end voltage 充电电压	4.2±0.05 V
Discharge cut-off voltage 放电终止电压	2.75±0.05 V
Standard charge and discharge current 标准充放电电流	0.5C (1000mA)
Max charge current 最大充电电流	0<T≤10°C: 0.2C 10<T≤20°C: 0.5C 20<T≤45°C: 1C
Charging Current 充电时间	Standard charge: 180mins
Max continuous discharge current 最大持续放电电流	-10<T≤0°C: 10A 0<T≤20°C: 15A 20<T≤60°C: 20A (25±3°C), after 300 cycles capacity≥80%
Max pulse discharge current (<1sec) 最大脉冲放电电流	30A (25±3°C)
Internal resistance 内阻	≤20 mΩ (AC Impedance, 1000 Hz)
Cell dimensions 电芯尺寸	Height: 65.5mm max 最大高度: 65.5mm Diameter: 18.6mm max 最大直径: 18.6 mm Weight: 42±2g 重量: 42±2g
Operating temperature 使用环境温度	Charge:0~ 45°C (充电时: 0~45°C) Discharge:-20~ 60°C (放电时: -20~60°C)
Storage Temperature 存储环境温度	1 month: -20~60°C (1 月内: -20~60°C) 3 months: -20~45°C (3 月内: -20~45°C) 1 year: -20~20°C (1 年内: -20~20°C)

4 Size and Appearance 尺寸及外观

4.1 Cell size 电芯尺寸

Diameter (直径): $18.6 \pm 0.3 \text{mm}$ (max.18.9mm)

Height (高度): $65 \pm 0.5 \text{mm}$ (max.65.5mm)

Weight (重量): $42 \pm 2 \text{g}$

Cell physical dimension listed in Figure 1 (unit: mm).

电芯尺寸示意图如图 1 所示 (单位: mm)。

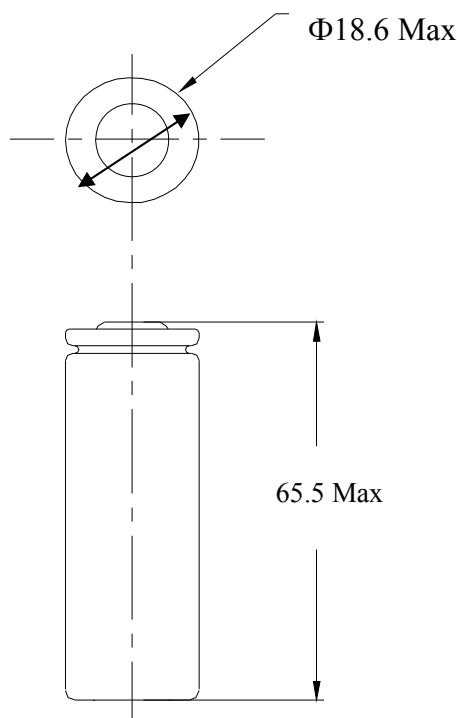

Figure 1/ 图 1

4.2 Cell appearance 电芯外观

There shall be no such defects as deep scratch, crack, rust, discoloration or leakage, which may adversely affect the commercial value of the cell.

电池外表面清洁, 无电解液泄露, 无明显的花痕迹机械损伤, 无变形, 无影响电池价值的其他外观缺陷。

5 Technical characteristics 技术要求

5.1 Cell testing conditions 电芯试验环境

Unless otherwise specified, all tests stated according to following:

除非有特殊说明, 所有测试的环境条件要求如下:

Temperature 温度: $25 \pm 2.5^\circ\text{C}$

Humidity range 湿度范围: 45%~85%

5.2 Requirement of the testing equipment 测量仪表要求

Voltage meter: The voltage tester internal resistance is $\geq 10 \text{K}\Omega/\text{V}$

电压仪表要求: 测量电压的仪表内阻不小于 $10\text{K}\Omega/\text{V}$

Temperature meter: The precision is $\leq 0.5^\circ\text{C}$

温度仪表要求: 测量温度的仪表精度不低于 0.5°C

5.3 Electric performance 电性能

NO. 序号	ITEM 检测项目	TESTING METHOD 测试条件与方法	CRITERION 性能标准
5.3.1	Standard charging 标准充电	Under 25±2.5°C charge to 4.2V with constant current of 0.5C, then charge continuously with constant voltage of 4.2V until the charged current is 0.01C. 指在 25±2.5°C 环境下,以 0.5C 的电流恒流充电至单体电芯电压 4.2 V 后,转为恒压 4.2 V 充电,至充电电流小于 0.01C 时,停止充电。	—————
5.3.2	Standard discharge 标准放电	Under 25±2.5°C discharge at 0.5C constant current down to 2.75V. 指在 25±2.5°C 环境下,以 0.5C 的电流恒流放电至单体电芯电压 2.75 V。	—————
5.3.3	Rated capacity 额定容量	Under 25±2.5°C, It means the capacity value of being discharged by 5-hours rate to end voltage 2.75 V, which is signed Cap, the unit is mAh. 指在 25±2.5°C 环境下,以 5 小时率放电至终止电压 2.75 V 时的容量,以 Cap 表示,单位为毫安培时(mAh)。	≥1900mAh
5.3.4	Discharge capacity 倍率放电	Under 25±2.5°C, after 0.5C standard charge rest for 10min and then discharge at 0.5C, 1C, 3C, 5C to the discharge cut-off voltage 2.75 respectively. Charge/discharge cycle can be conducted for 3 times before meeting the Standards 指在 25±2.5°C 环境下,以 0.5C 倍率将电池充满电后,搁置 10 分钟,分别以 0.5C、1C、3C、5C 倍率放电至 2.75V。循环三次,当有一次达到标准,即达到标准要求。	Discharge capacity/Nominal capacity*100% 放电容量/标称容量*100%
			0.5C≥100%
			1C≥97%
			3C≥95%
5.3.5	Temperature characteristics 温度放电	Under 25±2.5°C after 0.5C standard charge rest for 30min then set the temperature to the test value. Keep the cell stay the test temperature 16~24h then discharge at 0.2C to the discharge cut-off voltage 2.75V. 指在 25±2.5°C 环境下,以 0.5C 倍率将电池充满电后,在 30min 之内温度升/降至测试温度。在测试温度下搁置 16-24H 后,用 0.2C 放电至 2.75V。	Discharge capacity/25°C discharge capacity*100% 放电容量/标称容量*100%
			-10°C ≥60%
			0°C ≥80%
			25°C ≥100%
5.3.6	Charge retention 常温荷电保持能力	Under 25±2.5°C check the initial condition and initial capacity of battery. Store for 28 days after standard charge, check the final condition of battery. Then discharge at 0.5C to the discharge cut-off voltage 2.75V, check the residual capacity of battery. Test the capacity recovery of battery at 0.5C/0.5C. Charge/discharge cycle can be done 3 times before meeting the standards. 指在 25±2.5°C 环境下,测量电池初始状态和初始容量,电池标准充电后,开路放置 30 天,测量电池最终状态;以 0.5C 放电至 2.75V,测量电池剩余容量;0.5C/0.5C 测量电池的恢复容量。可循环三次,当有一次达到标准,即达到标准要求。	Residual capacity≥Nominal capacity*85% 剩余容量 ≥标称容量*85%
			Recovery capacity≥Nominal capacity*90% 恢复容量 ≥标称容量*90%
5.3.7	Cycle life 循环寿命	Under 25±2.5°C charge the battery at 0.5C, rest for 10min, discharge at 20A down to cut-off voltage. After discharging rest 10min, then do charge and discharge cycle more than 300 times. 指在 25±2.5°C 环境下,以 0.5C 充满电之后,搁置 10 分钟,用 1.3A 放电至终止电压,放电结束后搁置 10 分钟,再进行下一次充放电循环,连续进行充放电循环 300 次。	Capacity retention ≥80% 容量保持率≥80%
5.3.8	Storage 存储性能	Under 25±2.5°C,charge to the voltage of 3.80±0.02V,before storage,measured the initial condition and initial capacity of battery. Store for 3 months,6 months,12 months at room temperature,measured the final condition of battery.Then conduct 0.5C/0.2C cycle for 3 times to record the discharge time of the battery.指在 25±2.5°C 环境下,测量电池的初始容量,电池充电至 3.80±0.02V 后,测量电池存储前的初始状态,分别室温储存 3 月、6 月、12 月后,测量电池的最终状态,然后以 0.5C/0.2C 循环 3 次记录电池的放电时间。	the discharge time of 0.2C 0.2C 放电时间
			3 months (月) ≥4.5h
			6 months (月) ≥4.25h
			12 months (月) ≥4.0h

5.4 Mechanical characteristics

NO. 序号	ITEM 检测项目	TESTING METHOD 测试条件与方法	CRITERION 性能标准
5.4.1	Drop 跌落	Standard charge.Then let it self fall off from a height of 1m(the lowest height)to a smooth hardwood with the thick of 20mm.The drop is implemented totally for 3 times.Discharge at 1C to the cut-off voltage,then test the discharge time of the battery. 电池标准充电后，测量电池的初始状态，将电池样品由高度（最低点高度）为 1.0m 的位置从 XYZ 正负六个方向跌落到 20mm 厚木板上。跌落完成后测量电池的最终状态，然后以 1C 放电至 2.75V，测量电池的放电时间。	Exterior appearance apparent stain,leakage,somke and exposition. 电池无明显损伤，漏液，冒烟或是爆炸。 Discharge time \geq 51min. 1C 放电时间不少于 51min.
5.4.2	Vibration 振动	Standard charge.Install battery on the vibration table,adjust the equipment according to the following vibration and amplitude frequency.From X,Y,Z three directions in 10Hz~55Hz sweep vibration to sweep for 30mins with the sweep frequency speed rate at 1oct/min: Vibration frequency :10Hz~30Hz(single amplitude)、Displacement amplitude(single):0.38mm\Amplitude frequency:30Hz~55Hz(single amplitude)\Displacement amplitude (single):0.19mm 电池标准充电后，将电池安装在振动台面上，按下面振动频率和对应的振幅调整好实验设备。X,Y,Z 三个方向上每个方向上从 10Hz~55Hz 环扫频振动 30mins,扫频速度 1oct/min:振动频率：10Hz~30Hz、位移幅值（单幅）：0.38mm\振幅频率：30Hz~55Hz、位移幅值（单幅）：0.19mm	Exterior appearance apparent stain,leakage,somke and exposition. 电池无明显损伤，漏液，冒烟是爆炸。 Cell voltage no less than nominal voltage. 电池电压不低于标称电压。

5.5 Environmental characteristics 环境适应性能

NO. 序号	ITEM 检测项目	TESTING METHOD 测试条件与方法	CRITERION 性能标准
5.5.1	Heat cycle properties 温度循环	Standard charge.Put the battery into a 75 \pm 2 $^{\circ}$ C for 48h,then put it into a -20 $^{\circ}$ C for 6h,and then store it for 24h at room temperature.Observe the variation of the battery's appearance. 电池标准充电后，在环境温度为 75 \pm 2 $^{\circ}$ C 的条件下开路放置 48h，然后再 -20 $^{\circ}$ C 条件下开路放置 6h,最后在室温条件下开路放置 24h,观察电池外观变化。	Exterior appearance apparent stain,leakage,somke and exposition. 电池无明显损伤，漏液，冒烟或是爆炸。
5.5.2	Static humidity 恒温恒湿	Standard charge.Put the battery into a 40 \pm 5 $^{\circ}$ C and 95%RH chamber for 168h,then get it out and store it for 2h at room temperature.Observe the variation of the battery's appearance and then discharge at 1C to the cut-off voltage. 电池标准充电后，至于温度为 40 \pm 5 $^{\circ}$ C，相对湿度为 95%的恒温恒湿箱中，搁置 48h，取出电池搁置 2h,以 1C 放电至 2.75V.	Exterior appearance apparent stain,leakage,somke and exposition. 电池无明显损伤，漏液，冒烟或是爆炸。 Discharge time no less than 36mins. 电池 1C 放电时间不低于 36min.

5.6 Safety characteristics 安全性能

NO. 序号	ITEM 检测项目	TESTING METHOD 测试条件与方法	CRITERION 性能标准
5.6.1	Overcharge test 过充测试	The cell is discharged following the standard discharge method. Apply a 5V power supply and a 1C charge current for 3.5hrs. 电芯按照标准放电方式放完后，采用 1C 电流 5V 电压恒流恒压充电 3.5 小时。	No flame、No fire、No explode 电芯不冒烟、不起火、不爆炸
5.6.2	130°C hot oven test 130°C 热箱测试	The cell is charged following the standard charge method. After charging the cell is put in the oven. And then the oven temperature will be ramped at 5°C per minute to 130°C and held at 130°C. When the temperature of the cell reach 130°C, the cell is maintained in the 130°C oven for a maximum of 60 minutes or until a fire or explosion is obtained, whichever comes first. Record the time that the cell temperature reaches 130°C and the time when a fire or explosion occurs. 电芯按照标准充电方式充满电后，将电芯放进热箱里，然后将热箱按 5°C/min 升温到 130°C，当电芯的温度也达到 130°C 时，电芯在热箱 130°C 环境下保持 60 分钟或者电芯起火爆炸为止。记录电芯温度升至 130°C 起直到电芯起火或爆炸的时间。	When the temperature of the cell is 130°C. Cell must not fire or explode in 60 minutes 电芯表面温度达到 130°C 后的 60 分钟内，电芯不起火、不爆炸
5.6.3	Crush test 挤压测试	After charging a cell following the standard charge method, the cell shall be crushed between two flat surfaces. The direction of the crushing force shall be vertical to axis of the cylinder. The crushing force is to be applied by a hydraulic ram with a 32mm diameter piston. Crushing force is approximately 13 KN. Once the maximum pressure has been obtained it is to be released. 电芯按照标准充电方式充满电后，放在两个平整的表面进行挤压测试，压力器必须施加一个与圆柱电芯轴向垂直的力，平压于电芯。采用 32 mm 直径的液压活塞，所用压力为 13 KN，一旦达到最大压力值，即释放压力。	No flame、No fire、No explode 电芯不冒烟、不起火、不爆炸
5.6.4	Impact test 重物冲击测试	Cell shall first be charged according to standard charge method, then the battery cell was placed on a flat surface so that the longitudinal axis of the battery cell shall be parallel with it. A 7.9mm diameter bar is to be placed across the center of the sample. A 9.1kg weight is to be dropped from a height of 61cm on the sample. 电芯按照标准充电方式充满电后，水平放置于一个与电芯纵轴平行的平板。将一直径 $\Phi 7.9\text{mm}$ 的棒放在样品中心，让重量 9.1kg 的重物从 610mm 的高度落到实验电芯上。	No flame、No fire、No explode 电芯不冒烟、不起火、不爆炸

6 Handling of Cells (电池操作注意事项)

Prohibition short circuit (禁止电池短路)

Never make short circuit cell. It generates very high current which causes heating of the cells and may cause electrolyte leakage are very dangerous. The lithium ion tabs may be easily short-circuited by putting them on conductive surface. Such outer short circuit may lead to heat generation and damage of the cell. An appropriate circuitry with PCM shall be employed to protect accidental short circuit of the battery pack.

避免电池短路。短路会产生很高的电流而使电池发热以及电解液泄漏，产生有毒气体使非常危险的。极片连接在导电物体表面很容易短路，外部短路会导致发热及损坏电池。选用一个适当的保护电路可以在意外短路时保护电池。

7 Notice for Designing Battery Pack (电池外壳设计注意事项)

7.1 Pack toughness (外壳坚韧度)

Battery pack should have sufficient strength and the lithium ion cell inside should be protected from mechanical shocks.

电池外壳应该有足够的机械强度，使锂电池免受机械撞击。

7.2 Cell fixing (电池的固定)

The lithium ion cell should be fixed to the battery pack by its large surface area.

No cell movement in the battery pack should be allowed.

电池最大面积的一面应该固定在外壳上，安装后电池不能有松动。

7.3 Inside design (外壳内部设计)

No sharp edge components should be insides the pack containing the lithium ion cell.

外壳内安装电池的部位不应有锋锐边。

7.4 Tab connection (极片连接)

Spot welding is recommended for lithium ion tab connection method.

Battery pack should be designed that shear force are not applied to the lithium ion tabs.

If apply manual solder met hod to connect tab with PCM,below notice is very important to ensure battery performance:

The solder iron should be temperature controlled and ESD safe;

Soldering temperature should not exceed 350°C;

Soldering time should not be longer than 3s;

Soldering times should not exceed 5 times ,Keep battery tab cold down before next time soldrictlyg ;

Directly heat cell body is strictly prohibited ,Battery may damaged by heat above approx.100°C.

建议使用点焊焊接方法：外壳设计应考虑使极片不受外力。

如果使用人工焊接保护板，下面的注意事项对于确保电池性能非常重要：

焊接烙铁的温度必须可控且可防静电；

焊接时对烙铁的温度不能超过 350°C；

焊锡时间不能超过 3 秒钟；

焊锡次数不能超过 5 次，待极片冷却后才能进行下一次焊锡；

严禁直接加热电池，高于 100°C会损害电池。

7.5 For mishaps (针对意外事件)

Battery pack should be designed not to generate heat even when leakage occurs due to mishaps.

- 1) Isolate PCM (Protection Circuit Module) form leaked electrolyte as perfectly as perfectly as possible.
- 2) Avoid narrow spacing between bare circuit patterns with different voltage.(Including around connector)
- 3) Lithium ion battery should not have liquid from electrolyte ,but in case if leaked electrolyte as possible touch bare circuit patterns ,higher potential terminal material may dissolve and precipitate at the lower potential terminal ,and may cause short circuit ,The design of the PCM must have this covered.

发生意外时，外壳设计应考虑即使在电池出线漏液时也不会发热。

- 1) 尽量把保护电路与渗透的电解液隔离开。
- 2) 在不同的电压情况下避免出现小间距的裸露电路—包括插头的周围。
- 3) 锂电池不应该有来自电解液的液体，但是一旦发生电解液渗透触及裸露电路，高电势端接子材料可能会溶解然后沉淀到低电势端接子，可能会造成短路。保护板的设计须含有覆盖保护层。

8 Notice for Assembling Battery Pack (电池装配注意事项)

Shocks ,high temperature ,or contacts of sharp edge components should not be allowed in battery pack assembling process.

在电池装配过程中不允许撞击、高温或接触尖锐部分。

9 Others (其它)

9.1 Cell connection (电池连接)

- 1) Direct soldering of wire leads or devices to the cell is strictly prohibited.
- 2) Lead tabs with pre-soldering may cause damage of components ,such as separator and insulator .by heat generation.

-
- 1) 严禁直接焊接引线或设备到电池上。
 - 2) 极片在焊接引线之前应该先点焊到电池上，直接与电池热焊接，产生的热量会使电池的隔离体及绝缘体受损。

9.2 Prevention of short circuit within a battery pack (电池内部的短路预防)

Enough insulation layers between wiring and the cells shall be used to maintain extra safety protection. The battery pack shall be structured with no short circuit within the battery pack ,which may cause generation of smoke or firing.

在电池和引线之间应该有足够的绝缘层用于安全保护。电池的包装构成应没有导致起烟起火的短路情况。

9.3 Prohibition of disassembly (禁止拆卸)

1) Never disassemble the cells

The disassembling may generate internal short circuit in the cell ,which may cause gassing ,firing ,explosion ,or other problems.

2) Electrolyte is harmful

Lithium ion battery should not have liquid from electrolyte flowing ,but in case the electrolyte come into contace with the skin ,or eyes ,physicians shall slush the electrolyte immediately with fresh water and medical advice is to be sought.

1) 不要拆卸电池。

拆卸电池会发生电池内部短路，会引起起火、爆炸、有害气体或其它问题。

2) 电解液是有害的。

9.4 Prohibition of dumping of cells into fire (不要把电池倾倒入火中)

Never incinerate nor dispose the cells in fire .These may cause explosion of the cells ,which is very dangerous and is prohibition.

不要把电池浸泡在液体当中，像清水、海水及非酒精饮料、果汁、咖啡或其它的饮料中。

9.6 Battery cells replacement (更换电池)

The battery replacement shall be done only by either cells supplier or device supplier and never be done by the user.

更换电池应由电池生产商或设备供应商完成，用户不用自行更换。

9.7 Prohibition of use of damaged cells (禁止使用损坏的电池)

The cells might be damaged during shipping by shock .If any abnormal features of the cells are found such as damages in a plastic envelop of the cell ,deformation of the cell package ,smelling of an electrolyte ,an electrolyte leakage and others ,the cells shall never be used any more .The cells with a smell of the electrolyte or a leakage shall be placed away from fire to avoid firing or explosion.

电池可能在出货途中碰撞而受损。如果发现电池有异常，例如包装损坏、包装包裹变形，有电解液的味道、发现漏液等等，不要再使用这些电池如果有电解液的味道或出现漏液，电池放置应该远离火源避免起火爆炸。

10 Period of Warranty (保质期)

The period of warranty is one year from the date of shipment . Masscore guarantees to give a replacement in case of cells with defects proven due to manufacturing process instead of the customer abuse and misuse.

电池的保质期从出厂日期（喷码）开始起 1 年。如果证明电池的缺陷是在制造过程中形成的而不是由于用户滥用及错误使用造成，伊可芯公司负责退换电池。

11 Storing the Batteries (电池的存放)

The batteries should be stored at room temperature ,charged to about 30% to 50% of capacity .We recommend that batteries be charged about once per half a year to orevent over discharge.

电池应当在温室下存放，应充到 30%至 50%的电量。如长时间储存，建议每半年充一次电，以防止电池过放电。

12 Other The Chemical Reaction (其它的化学反应)

Because the battery is the use of the principle of chemical reaction ,battery performance over time even if stored for a long period of time without being used . In addition ,if the various usage conditions such as charge ,ambient temperature ,etc .are not maintained within the specified ranges the life expectancy of the battery may be shortened or the device in which the battery is used may be damaged by electrolyte leakage .if the batteries cannot maintain a charge for long periods of time ,even when they are charged correctly ,this may indicate it is time to change the battery.

由于电池是利用化学反应的原理，所以随时间的增加电池的性能会降低，即使是存放很长一段时间而不使用。如果使用条件如充电、放电及周围环境温度等情形不在指定的使用范围内，会缩短电池的使用寿命，或者会产生漏液导致设备损坏。如果电池长时间不能充电，即使充电方法正确，就要更换电池了。

Note: (注释)

Any other items which are not covered in this specification shall be agreed by both parties.

本说明书包括事项应由双方协议确定。